

No. 9198

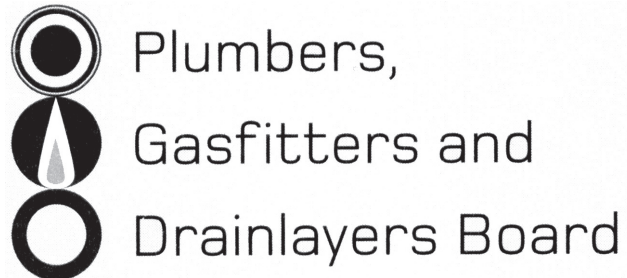

REGISTRATION EXAMINATION, JUNE 2016  
**CERTIFYING DRAINLAYER**

ANSWER SCHEDULE

## ANSWER 1

Drawing to show:

Inspection or rodding points at B, C or D, D or E, F

Use 50 m rule

(4 marks)

**Total 8 marks**

## ANSWER 2

(a) Any FIVE (1 mark each)

Is the manhole discharging to a tidal area causing conditions within the chamber to change over time?

Have steps been taken to ensure nothing will discharge into the chamber during work?

Has the chamber been identified correctly – e.g. location, surface water or foul water?

Is the atmosphere in the chamber safe (will breathing equipment be required)?

Are there safe means of retrieval should a worker become injured or un-responsive during work?

Is a spotter available to sound the alarm and assist if needed?

Is there a reliable source of communication between workers in the chamber and the spotter?

Has heavy rainfall occurred in the area that may find its way to the drainage system and effect the air and water level in the chamber?

Is the work area fenced off?

Is the access ladder in good condition?

(5 marks)

(b) (i) WorkSafe New Zealand

(1 mark)

(ii) 24 hours

(1 mark)

(c)

	Notifiable work Yes/No
Working in a trench that is 1.8 metres deep and 1.5 metres wide	Yes
Replacing worn asbestos sewer pipe work	Yes
Working in a trench 1.6 metres deep where the excavated face has been cut back to a 60° angle.	No
Using explosives to break up rock	Yes

(2 marks)

**Total 9 marks**

### ANSWER 3

- (a) Any FOUR ( $\frac{1}{2}$  mark each)  
Telecommunications.  
Reticulated Gas.  
Electricity.  
Water.  
Drainage (2 marks)
- (b) Before work starts each day.  
After rain.  
After any occurrence that could affect the stability of an excavated face. (3 marks)
- (c) 310 mm (1 mark)
- Total 6 marks**

### ANSWER 4

- (a) A main through which water or sewage is pumped at pressure. (1 mark)
- (b) Rising mains shall be free of leaks when subject to a pressure test at a pressure of not less than twice the shut-off head of the pump connected to the rising main, for a period of not less than 10 minutes. (2 marks)
- (c) Any TWO ( $\frac{1}{2}$  mark each)  
Inspection chamber.  
Boundary trap shaft.  
A stack below the lowest fixture connection on any floor.  
A drain or combined discharge pipe, provided the connection is at least 2.5 m from any other connection.  
Downstream of a reflux valve or at least 2.5 m upstream of a reflux valve.  
A minimum of 1 m downstream of a boundary trap.  
Direct to the network utility operator's sewer where approved by the network utility operator. (2 marks)
- Total 5 marks**

## ANSWER 5

- (a) A tank that receives grey water waste only – no human waste is to discharge to a sullage tank. (1 mark)
- (b) Any ONE (1 mark)  
When grey water is to be recycled as a non-potable water supply.  
When greywater is discharged directly to ground. (1 mark)
- (c) (i) Diagram with tanks (1 mark)  
Correct fixtures to sullage tank (1 mark)  
WC to septic tank (1 mark)  
Vents installed at correct locations (2 marks)  
Inspection points and fresh air inlets where required (4 marks)  
Overflow relief gully (1 mark) (10 marks)
- (ii) 2500 litres (1 mark)
- (iii)  $L = \frac{180 \times 6}{35 \times 0.9} = 34.28 \text{ m}$  (2 marks)

**Total 15 marks**

## ANSWER 6

- (a) Foul water section:  
Correct vent (1 mark)  
Correct overflow relief gully (1 mark)  
Correct inspection opening (1 mark)  
Location of grease trap (1 mark)  
Correct fittings discharging to grease trap (1 mark)  
Drain attached to correct connection point (1 mark)
- Surface water section:  
Branch drain to downpipe A shown as 90 mm (1 mark)  
Branch drain to a Type 2 sump shown as 150 mm (1 mark)  
Main drain from boundary to first branch drain 150 mm (1 mark)  
Drain attached to correct connection point (1 mark)
- Design:  
Design is consistent with trade practice and is economical (3 marks) (13 marks)
- (b)  $160 \times 5 = 800$  litres (1 mark)

**Total 14 marks**

## ANSWER 7

(a)

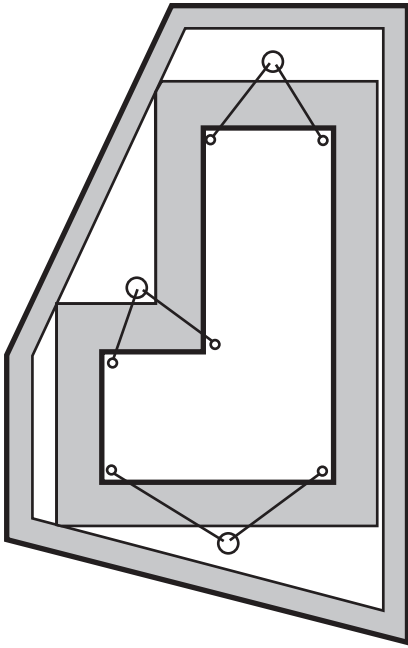

(3 marks)

(b) Total area of roof from scale drawing = 200.8 m<sup>2</sup> (4 marks)

$200.8 \times 0.037 = 7.43 \text{ m}^3$  rainfall (2 marks)

$7.43 \div 5 = 1.543$  soak hole

So need 2 soak pits (2 marks)

(8 marks)

**Total 11 marks**

## ANSWER 8

(a) 1.65% or 1:60 (1 mark)

(b) Are there any soil fixtures connected to the drain?

What is the discharge unit loading for the drain?

Will a method to flush the drain need to be included in the system? (3 marks)

(3 marks)

**Total 4 marks**

## ANSWER 9

Sumps to petrol trap  
Downpipes do not discharge to sump or petrol trap  
Storm water connected to NUO sewer

**Total 3 marks**

## ANSWER 10

Correct scale	(1 mark)
Walls and fixtures located correctly	(2 marks)
IO included at WC branch	(1 mark)
New vent – in correct location	(1 mark)
GT for basin	(1 mark)

**Total 6 marks**

## ANSWER 11

Sumps direct to water course	(2 marks)
Drains correctly to tanks	(2 marks)
Tank overflow to water course	(1 mark)

**Total 5 marks**

## SECTION B

1. E A Department of Labour preferred work practice guideline.
2. A To recover plant and equipment from the site.
3. C Extra weight from soil or vehicles near the edge of the trench.
4. A To allow a drain to be laid within a neighbouring property.
5. C The drain must not be collapsed.
6. D Cesspit/stormwater sump cleanings.
7. E Telecommunications.
8. E 60 m.
9. D The branch drain and junction receiving the waste from the gully dish should be
10. D 150 mm.
11. D 3.0 m.
12. A To stop the waste cooling and fats solidifying on the internal wall of the pipe.
13. B 175 mm.
14. A 1:50 (2.00%).
15. E 9.60 m.

**Total 15 marks**